



Instruction Manual Book

Glow and EP

EXCEL 2000



95% ALMOST READY TO FLY

SPECIFICATION

- Wingspan: 1,550 mm (61.02 in).
- Length: 1,340 mm (52.76 in).
- Weight: 2.5 kg (5.5 lbs).
- Wing area: 41.3 dm².
- Wing loading: 60.5g/dm².
- Servo mount: 42mm x 21mm.
- Wing type: Naca Airfoil.
- Spinner: 58mm
- Gear type: Aluminium Hi-grade for main gear and wire nose gear (included).

Parts listing required (not included):

- Engine: 40 - 46 cu.in 2 stroke; 52 cu.in 4 stroke.
- Radio: 04 channels.
- Servo: 05 servos.
- Motor: Brushless outrunner 1000-1800W, 800KV.
- Propeller: Suit with your engine.

Recommended Motor

and Battery set up (not included) :

- Motor: RIMFIRE.55.
- Lipo cell: 6 cells 4,000-5,000mAh.
- ESC: 60A .

Made in Vietnam.

EXCEL 2000.

This instruction manual is designed to help you build a great flying aeroplane. Please read this manual thoroughly before starting assembly. Use the parts listing below to identify all parts.

WARNING.

Please be aware that this aeroplane is not a toy and if assembled or used incorrectly it is capable of causing injury to people or property. WHEN YOU FLY THIS AEROPLANE YOU ASSUME ALL RISK & RESPONSIBILITY.

If you are inexperienced with basic R/C flight we strongly recommend you contact your R/C supplier and join your local R/C Model Flying Club. R/C Model Flying Clubs offer a variety of training procedures designed to help the new pilot on his way to successful R/C flight. They will also be able to advise on any insurance and safety regulations that may apply.

WARRANTY

Black Horse Model guarantees the component parts in this kit to be free from defects in both material and workmanship at the date of purchase by the purchaser.

This warranty does not cover cosmetic damage or damage due to acts of God, accident, misuse, abuse, negligence, commercial use, or modification of or to any part of the Product.

This warranty does not cover damage due to improper installation, operation, maintenance, or attempted repair by anyone other than Black Horse Model.

Return only the component part that is defective in materials or workmanship. Please pack the unit carefully and insure it, as this warranty does not cover loss or damage in transit.

DISCLAIMER

Read this disclaimer carefully before using this product. Please strictly follow the instruction manual to assemble and use this.

In that Black Horse Model has no control over the final assembly or material used for final assembly, black Horse Model is not responsible for loss of use, or other incidental or consequential damages.

Furthermore, Black Horse Model cannot be held liable for personal injury or property damage caused by the use or misuse of Black Horse Model products. By the act of using the user-assembled products, the user accepts all resulting liability.

PARTS LISTING.

FUSELAGE ASSEMBLY

- (1) Fuselage.

WING ASSEMBLY

- (1) Right wing half with pre-installed aileron.
- (1) Left wing half with pre-installed aileron.

Tail section assembly

- (1) Vertical stabilizer with pre-installed rudder.
- (1) Horizontal stabilizer with pre-installed elevator halves.

Some more parts.

HARDWARE PACK

COWLING.

Landing gear.....

TOOLS & SUPPLIES NEEDED.

- Thick cyanoacrylate glue.
- 30 minute epoxy.
- 5 minute epoxy.
- Hand or electric drill.
- Assorted drill bits.
- Modelling knife.
- Straight edge ruler.
- 2mm ball driver.
- Phillips head screwdriver.
- 220 grit sandpaper.
- 90° square or builder's triangle.
- Wire cutters.
- Masking tape & T-pins.
- Thread-lock.
- Paper towels.

SUGGESTION.

To avoid scratching your new airplane, do not unwrap the pieces until they are needed for assembly. Cover your workbench with an old towel or brown paper, both to protect the aircraft and to protect the table. Keep a couple of jars or bowls handy to hold the small parts after you open the bag.

NOTE.

Please trial fit all the parts. Make sure you have the correct parts and that they fit and are aligned properly before gluing! This will assure proper assembly. This kit is hand made from natural materials, every plane is unique and minor adjustments may have to be made. However, you should find the fit superior and assembly simple.

The painted and plastic parts used in this kit are fuel proof. However, they are not tolerant of many harsh chemicals including the following: paint thinner, C/A glue accelerator, C/A glue debonder and acetone. Do not let these chemicals come in contact with the colors on the covering and the plastic parts.

Instruction Manual.

SAFETY PRECAUTION.

- + This is not a toy
- + Be sure that no other flyers are using your radio frequency.
- + Wear safety glasses.
 - + Keep loose clothing and wires away from the propeller.
 - + Do not start the engine if people are near.
- Do not stand in line with the side of the propeller.
- + Make engine adjustments from behind the propeller only. Do not reach around the spinning propeller.



SERVO INSTALLATION.

INSTALLING THE AILERON SERVOS.

1. Install the rubber grommets and brass eyelets onto the aileron servo.

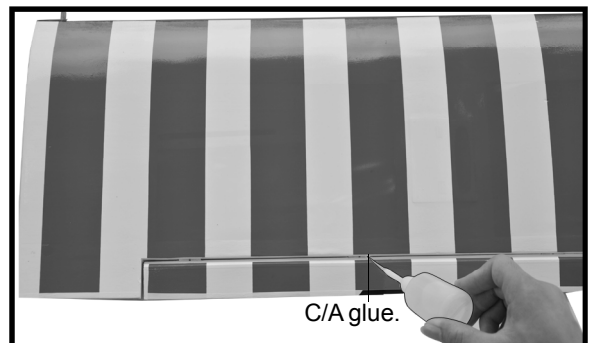
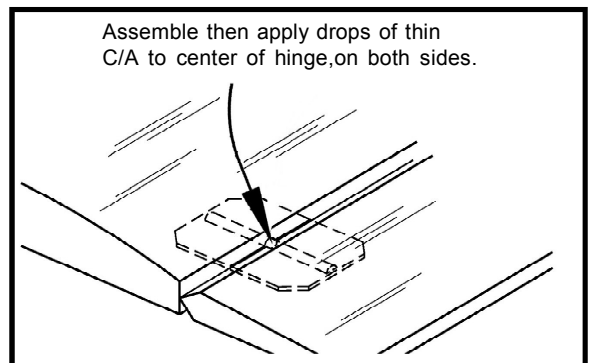
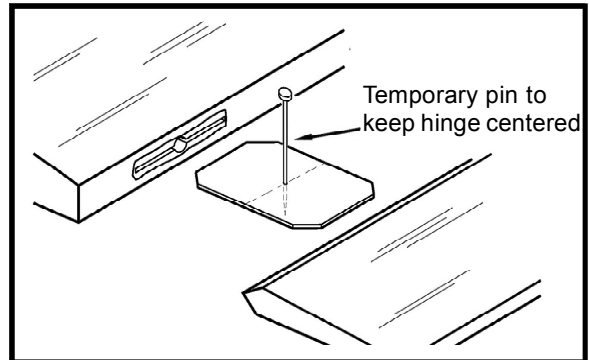
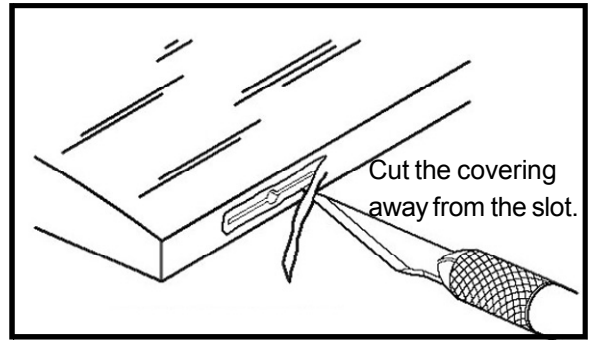
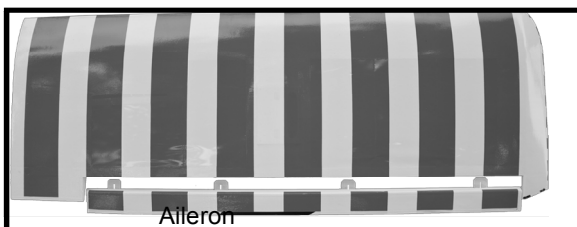
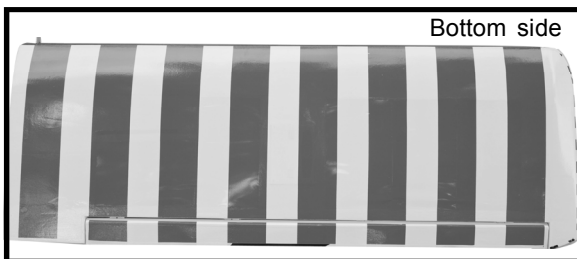

Repeat the procedure for the other top wing.

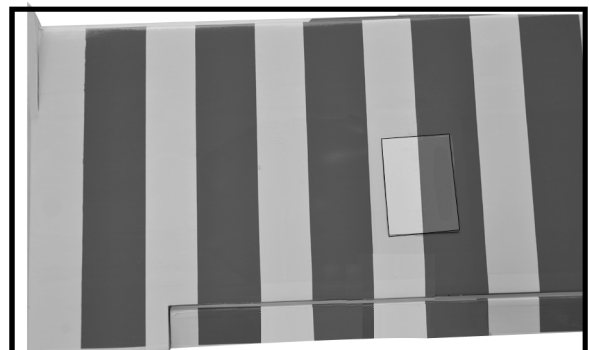

EXCEL 2000.

□ 2. Using a modeling knife, remove the covering servo tray.

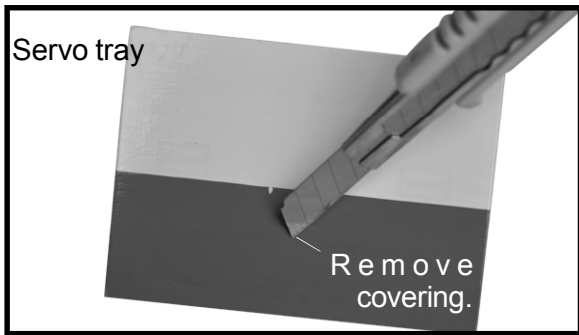

□ 3. Drill 1,5mm pilot holes through the block of wood for each of the four mounting screws provided with the servo. Install servo into aileron servo tray as same as picture below.

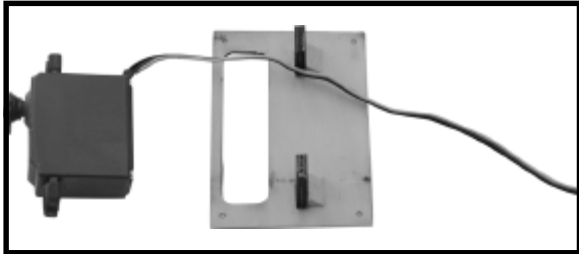

□ 4. Using the thread as a guide and using masking tape, tape the servo lead to the end of the thread: carefully pull the thread out. When you have pulled the servo lead out, remove the masking tape and the servo lead from the thread.

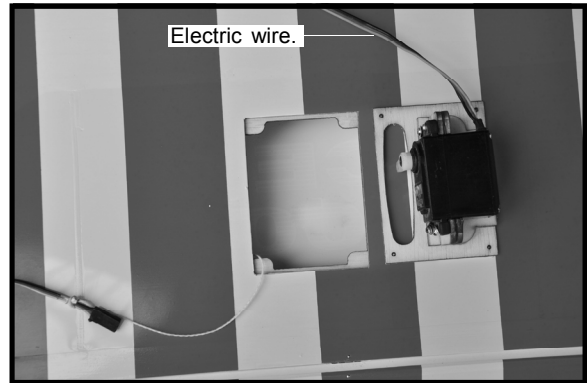
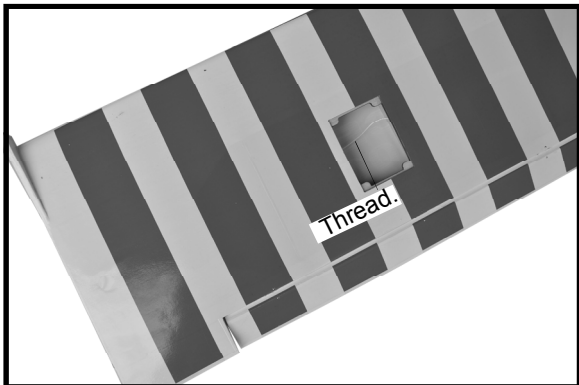
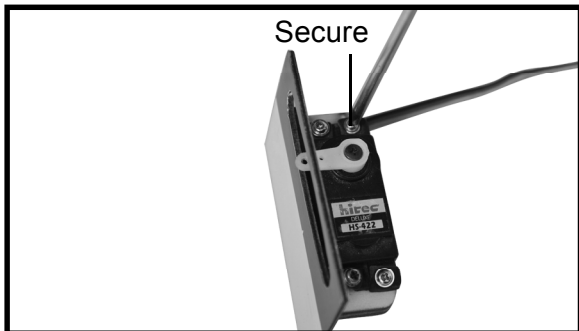

□ 5. Instal servo tray with aileron servo into the wing as same as picture below.

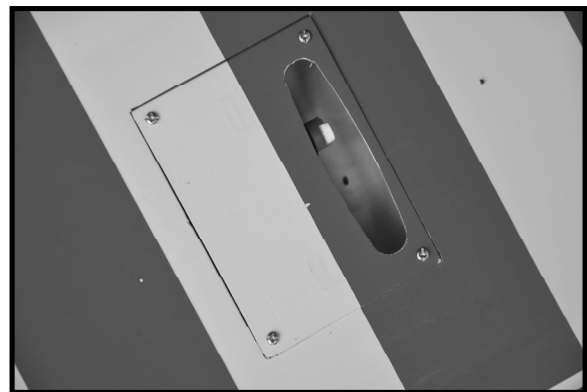
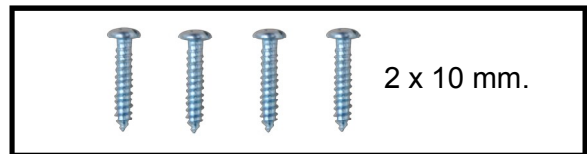

Repeat the procedure for the other wing half.

INSTALLING THE AILERON CONTROL HORN.

Install aileron control horn as same as picture below.

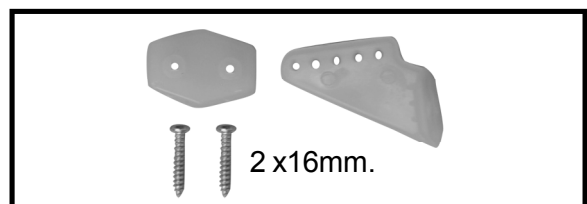

Control horn of Aileron

Instruction Manual.

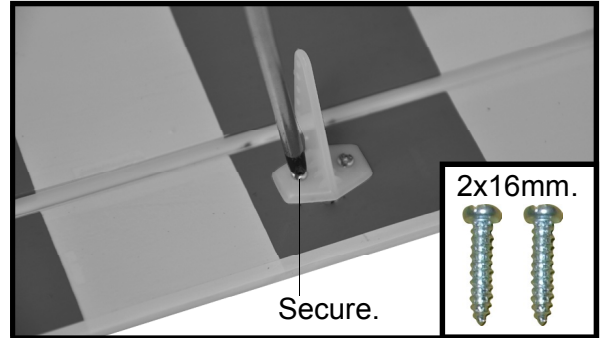
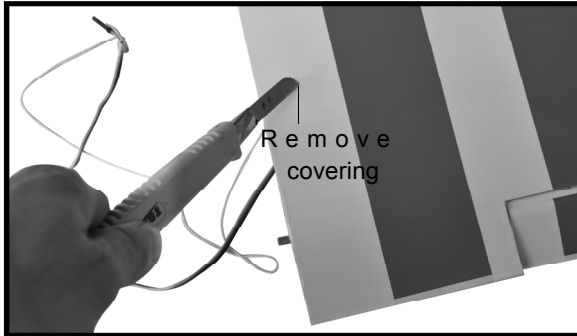
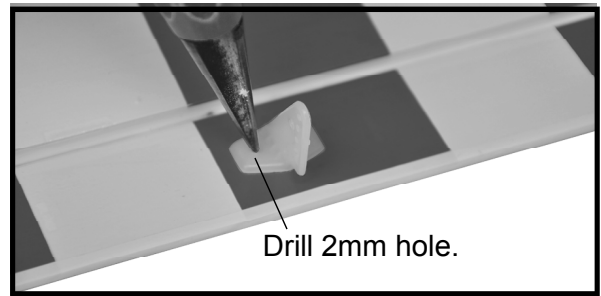
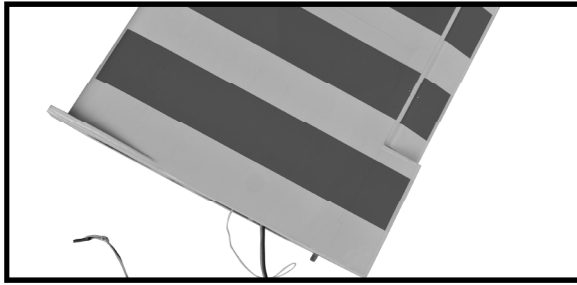

INSTALLING THE AILERON LINKAGES.

Installing the aileron linkages as pictures below.

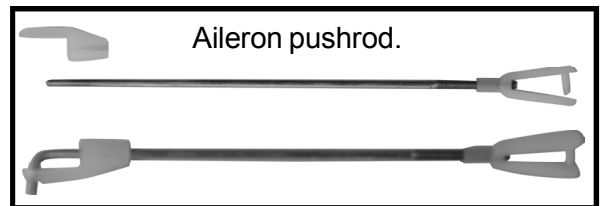

□ 1. Using a ruler & pen to draw a straight line as below picture.

□ 2. Locate nylon control horn, nylon control horn backplates .

Attach the clevis to the outer hole in the control horn.

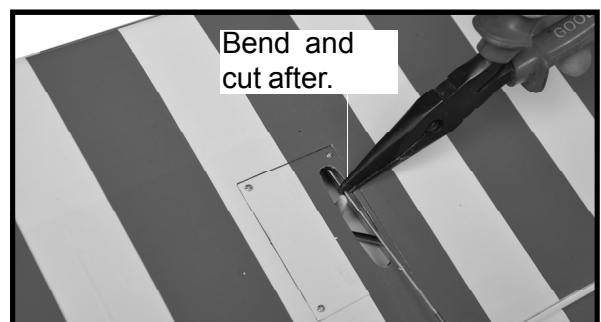
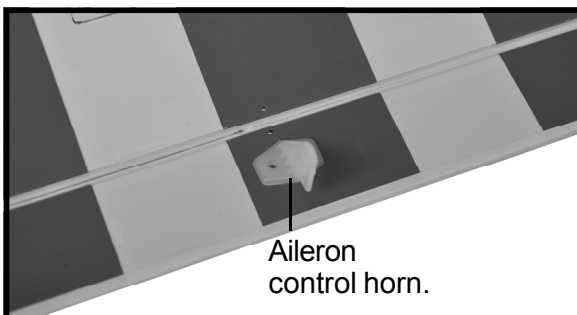
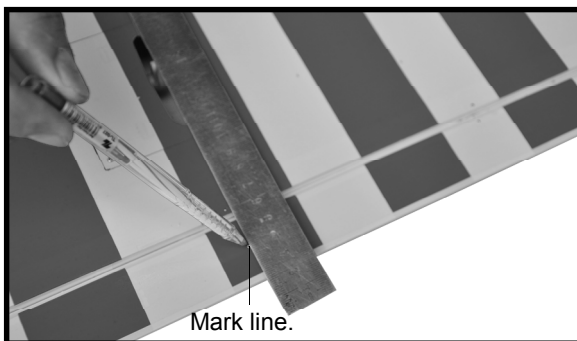

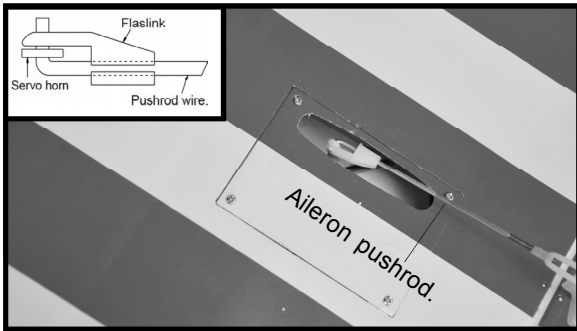
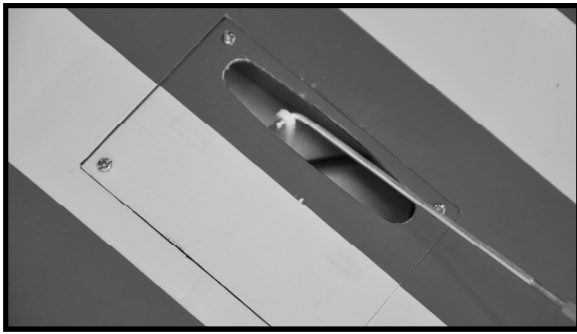

Repeat the procedure for the other wing half.

WING ASSEMBLY.

- 1) Location the aluminium wing dihedral brace.



- 2) Test fit the dihedral brace into each wing half. The brace should slide in easily. If not, use 220 grit sandpaper with a sanding block and sand down the edges and ends of the brace until it fits properly.

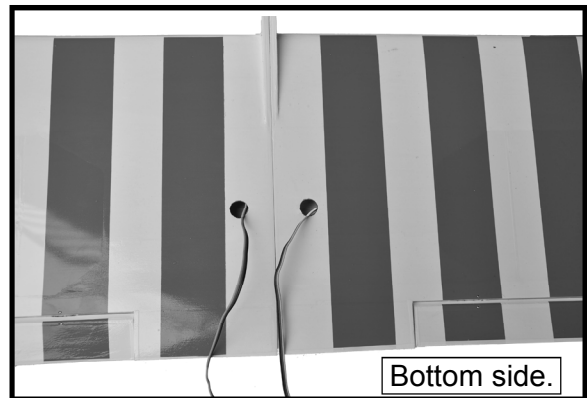
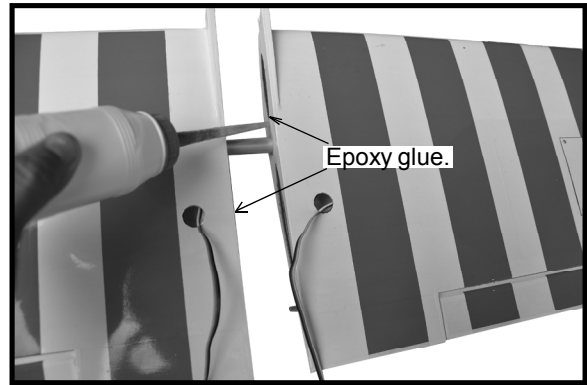
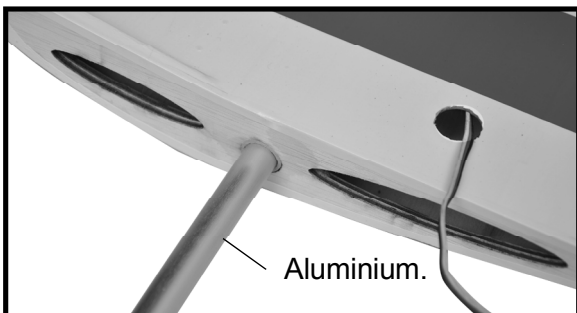

INSTALLING THE ENGINE MOUNT.

There are two options:

1. Electric motor
2. Engine mount.

OPTION 1: ELECTRIC MOTOR

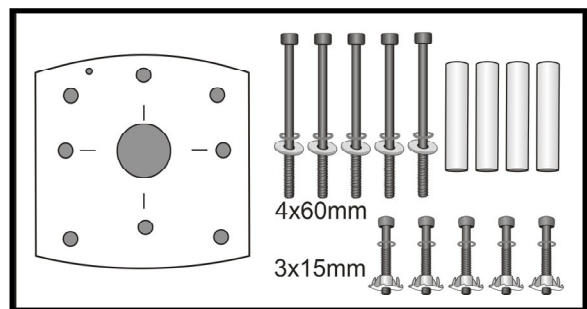

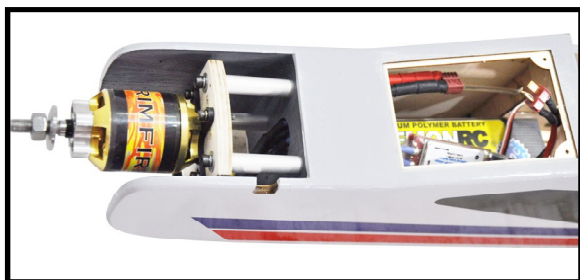

OPTION 2: ENGINE MOUNT

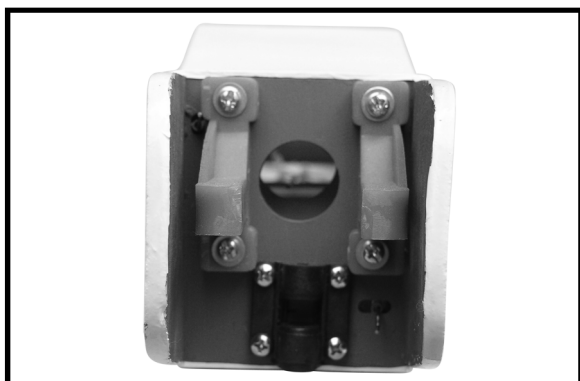

FUEL TANK.

INSTALLING THE STOPPER ASSEMBLY

□ 1) The stopper has been pre-assembled at the factory.

□ 2) Using a modeling knife, cut one length of silicon fuel line (the length of silicon fuel line is calculated by how the weighted clunk should rest about 8mm away from the rear of the tank and move freely inside the tank). Connect one end of the line to the weighted clunk and the other end to the nylon pick up tube in the stopper.

□ 3) Carefully bend the second nylon tube up at a 45 degree angle (using a cigarette lighter). This tube will be the vent tube to the muffler.

□ 4) Carefully bend the third nylon tube down at a 45 degree angle (using a cigarette lighter). This tube will be vent tube to the fueling valve.

When the stopper assembly is installed in the tank, the top of the vent tube should rest just below the top surface of the tank. It should not touch the top of the tank.

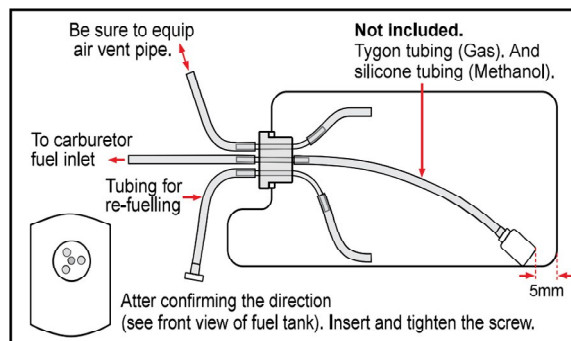
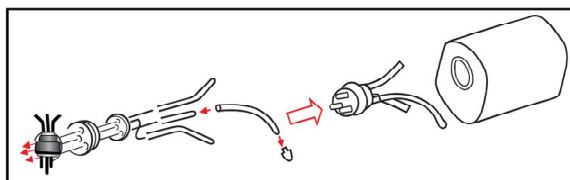

□ 5) Test fit the stopper assembly into the tank. It may be necessary to remove some of the flashing around the tank opening using a modeling knife. If flashing is present, make sure none of it falls into the tank.

□ 6) When satisfied with the alignment of the stopper assembly tighten the 3mm x 20mm machine screw until the rubber stopper expands and seals the tank opening. Do not over tighten the assembly as this could cause the tank to split.

□ 7) Using a modeling knife, cut 3 lengths of fuel line 150mm long. Connect 2 lines to the 2 vent tubes and 1 line to the fuel pickup tube in the stopper.

□ 8) Feed three lines through the fuel tank compartment and through the pre-drilled hole in the firewall. Pull the lines out from behind the engine, while guiding the fuel tank into place. Push the fuel tank as far forward as possible, the front of the tank should just about touch the back of the firewall.

Blow through one of the lines to ensure the fuel lines have not become kinked inside the fuel tank compartment. Air should flow through easily.

□ 9) To secure the fuel tank in place, apply a bead of silicon sealer to the forward area of the tank, where it exits the fuselage behind the engine mounting box and to the rear of the tank at the forward bulkhead.

Do not secure the tank into place permanently until after balancing the airplane. You may need to remove the tank to mount the battery in the fuel tank compartment.

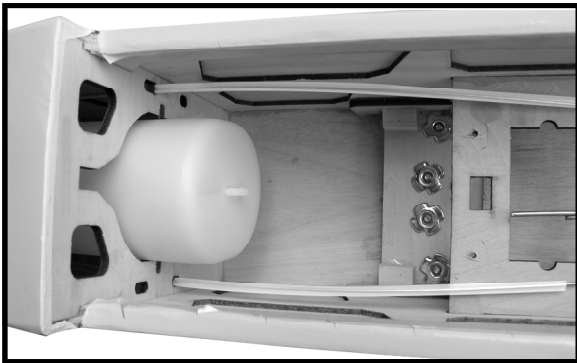
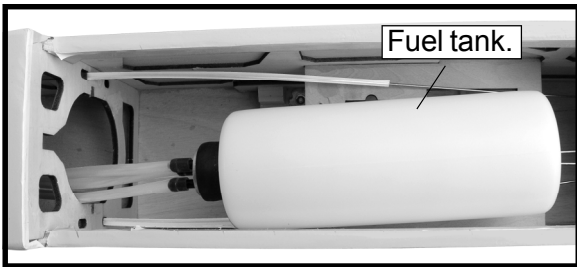
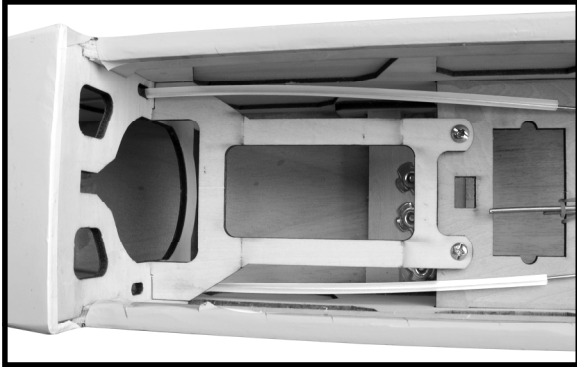

INSTALLING THE ENGINE.

Locate the long piece of wire used for the throttle pushrod. One end of the wire has been pre-bend in to a "Z" bend at the factory. This "Z" bend should be inserted into the throttle arm of the engine when the engine is fitted onto the engine mount. Fit the engine to the engine mount using the screws provided.

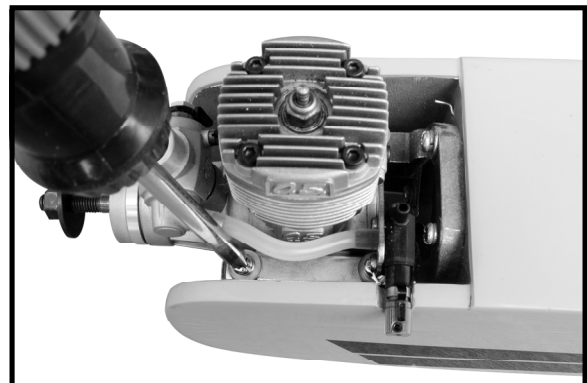
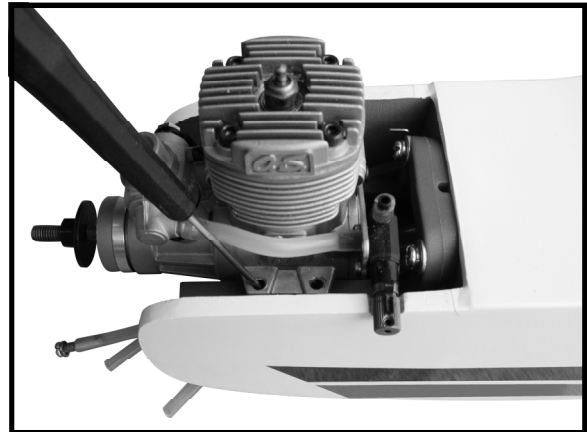
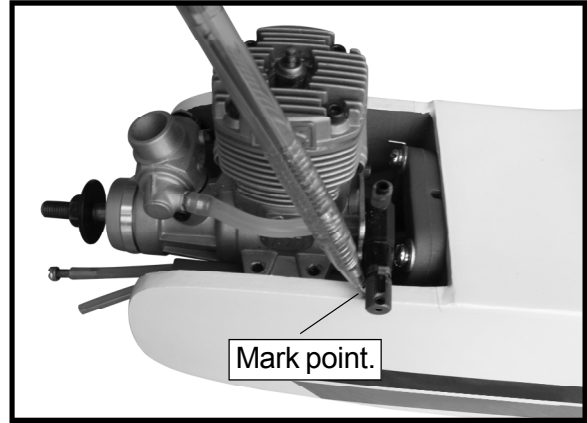

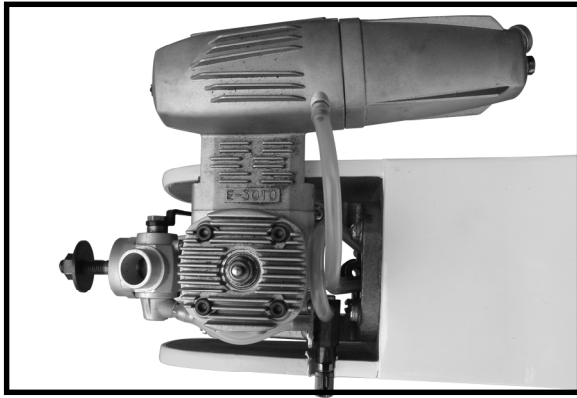

NOSE GEAR INSTALLATION.

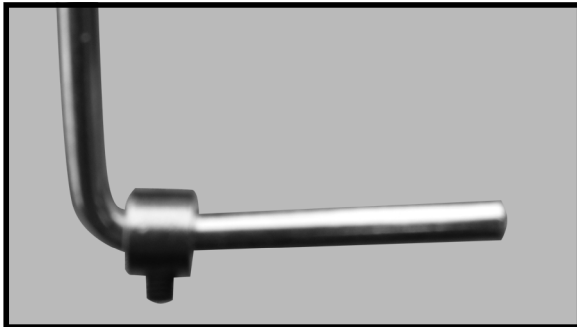
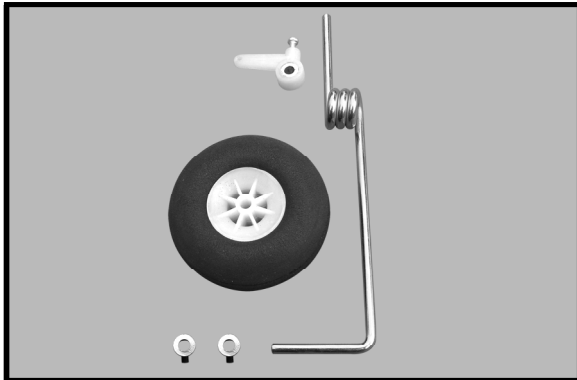

Installing steering arm as follow

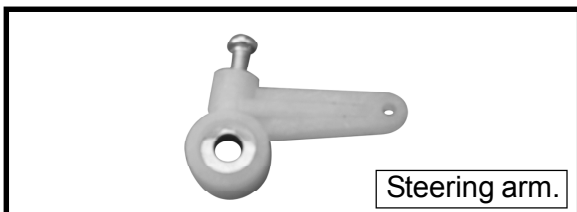

Adjust the nose gear steering arm until the arm is parallel with the fire wall.

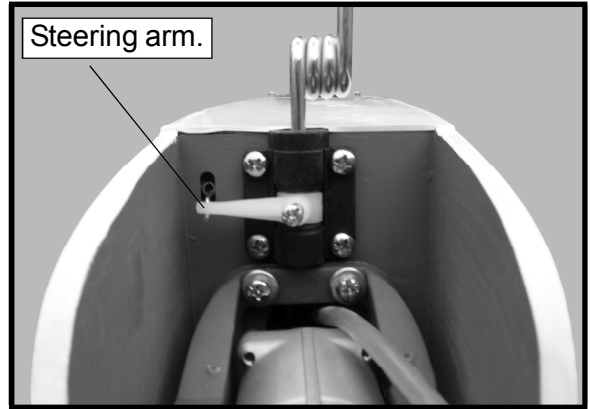

INSTALLING THE SPINNER.



Install the spinner backplate, propeller and spinner cone. The spinner cone is held in place using two 3mm x 12mm wood screws.

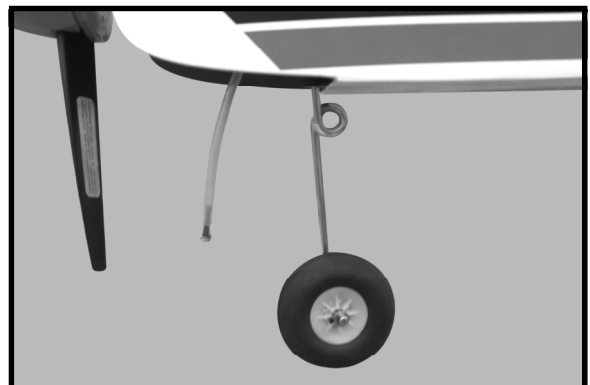
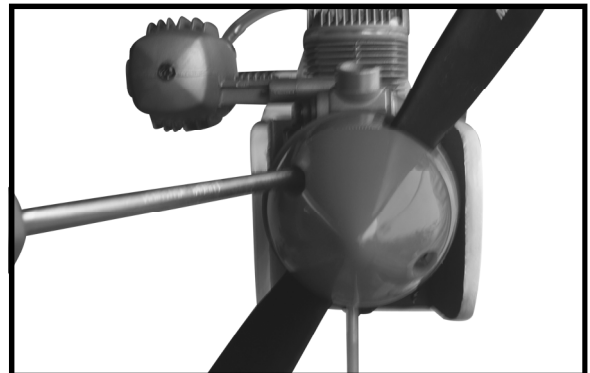

MAIN GEAR INSTALLATION.

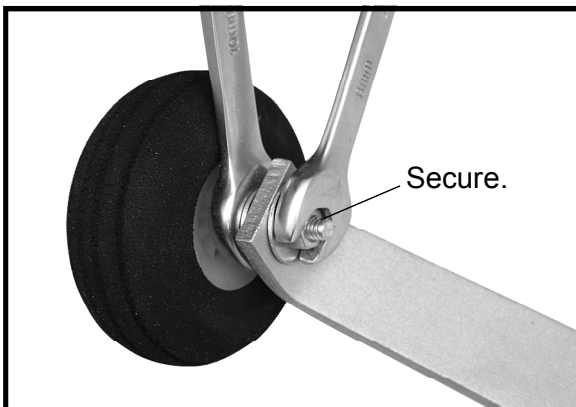
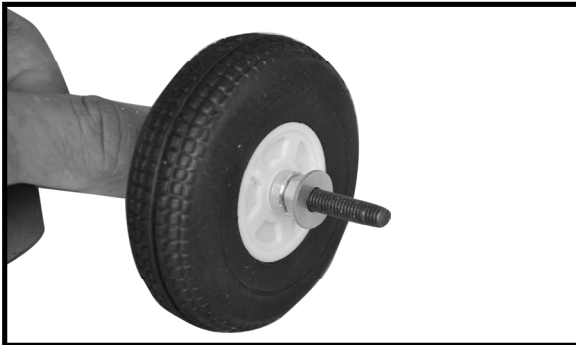
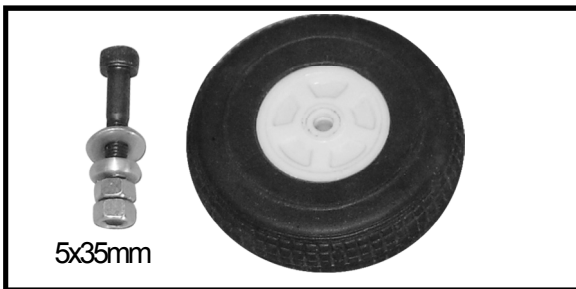
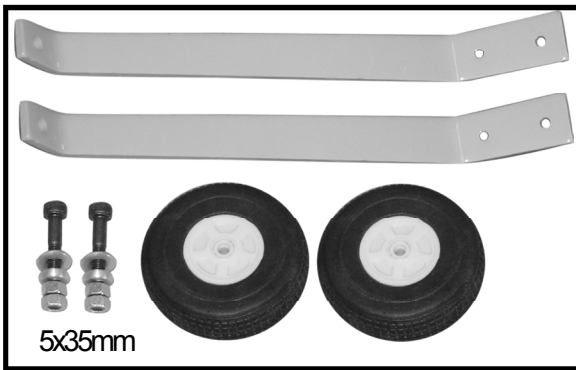

- 1) Using a modeling knife, remove the covering from over the two main gear mounting slots located in the bottom of the fuselage.
- 2) Using the two landing gear straps as a guide, mark the locations of the four mounting screws onto the fuselage surface.
- 3) The landing gear wire is held in place using two nylon landing gear straps and four wood screws.

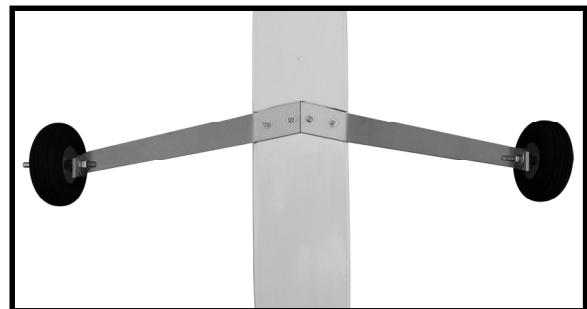
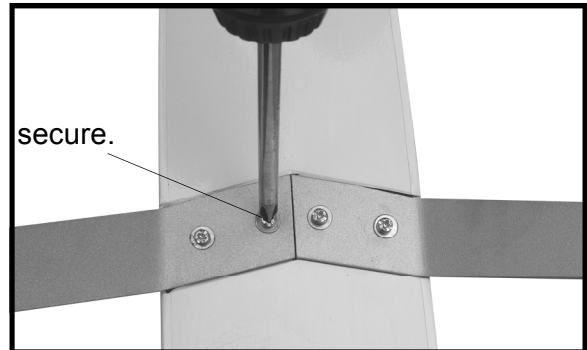

ELEVATOR SERVO INSTALLATION.

See pictures below:

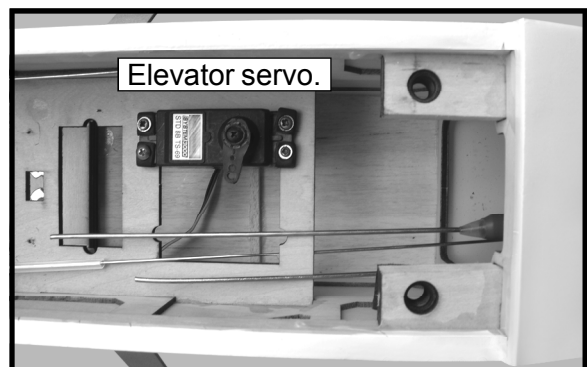

HORIZONTAL STABILIZER.

- 1) Using a modeling knife, carefully remove the covering from over the vertical stabilizer mounting slot in the top of the fuselage.

Instruction Manual.

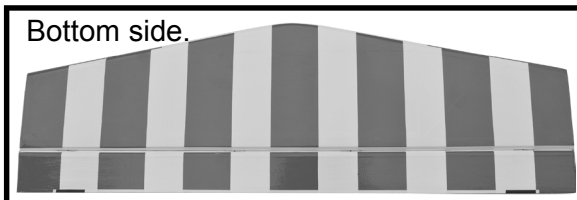
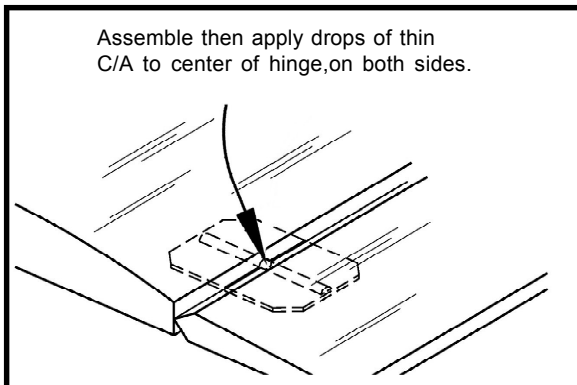
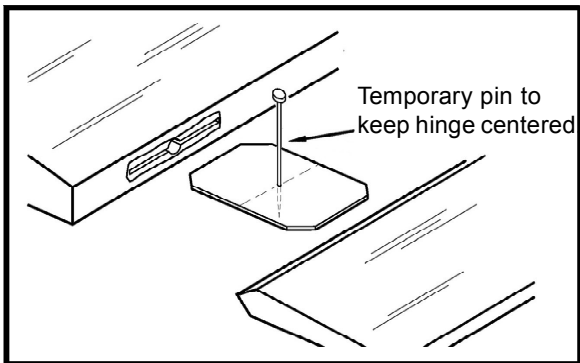
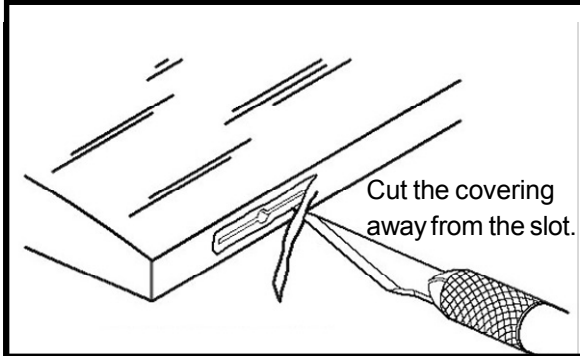
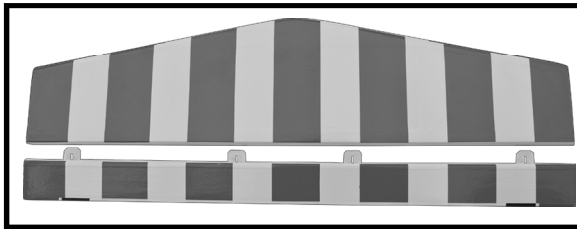

□ 2. Draw a center line onto the horizontal stabilizer. Then slide the horizontal into the fuselage.

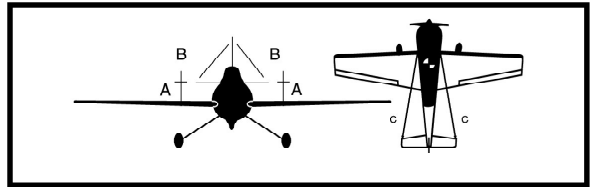
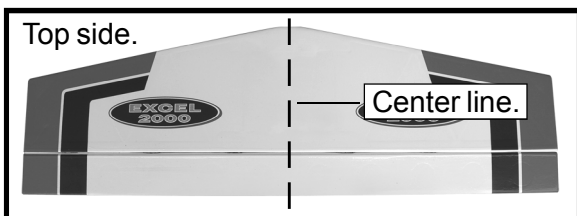

Check to make sure the wing and stabilizer are parallel. If they are not, lightly sand the opening in the fuselage for the stabilizer until the stabilizer is parallel to the wing.

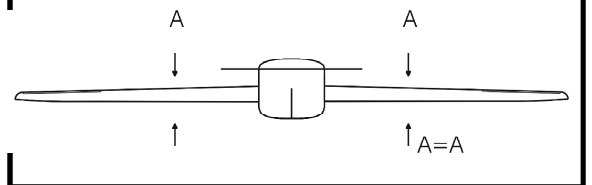

The top of the stabilizer does not have the hinge pins exposed.

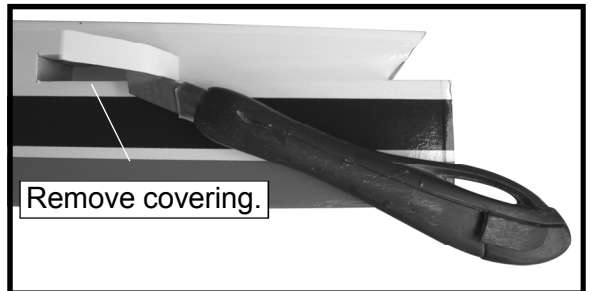

□ 3) Slide the stabilizer into place in the fuselage. Use a pen and draw lines onto the stabilizer where it and the fuselage sides meet.

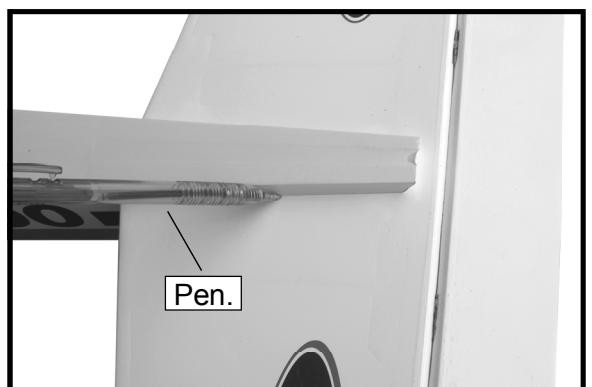

□ 4) Remove the stabilizer. Using the lines you just drew as a guide, carefully remove the covering from between them using a modeling knife.

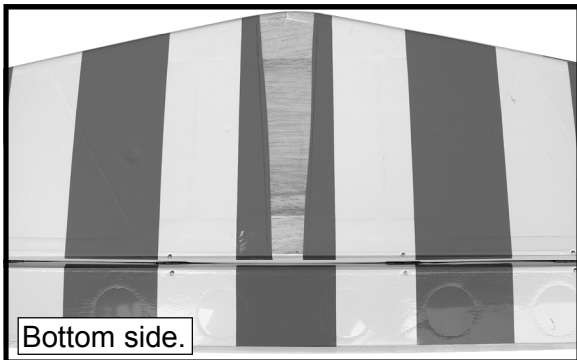
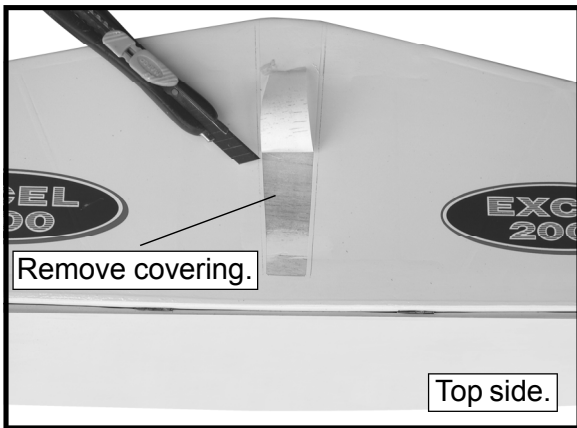

When cutting through the covering to remove it, cut with only enough pressure to only cut through the covering itself. Cutting into the balsa structure may weaken it.

□ 5) When you are sure that everything is aligned correctly, mix up a generous amount of 30 Minute Epoxy. Apply a thin layer to the top and bottom of the stabilizer mounting platform sides in the fuselage. Slide the stabilizer in place and realign. Double check all of your measurements once more before the epoxy cures. Hold the stabilizer in place with T-pins or masking tape and remove any excess epoxy using a paper towel and rubbing alcohol.

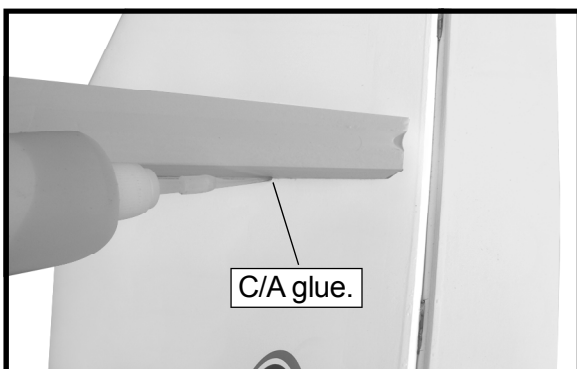
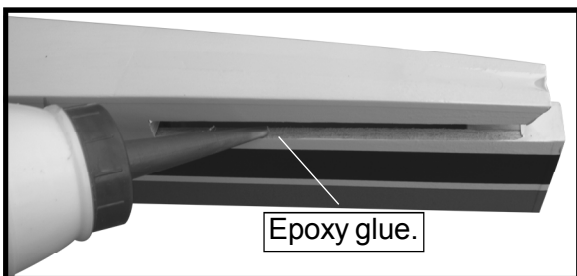

□ 6) After the epoxy has fully cured, remove the masking tape or T-pins used to hold the stabilizer in place. Carefully inspect the glue joints. Use more epoxy to fill in any gaps that may exist that were not filled previously and clean up the excess using a paper towel and rubbing alcohol.

ELEVATOR CONTROL HORN PUSHROD INSTALLATION.

□ 1) Locate the two nylon control horns, two nylon control horn backplates and four M2 x 12mm machine screws.

□ 2) Position the elevator horn on the bottom side of elevator. The clevis attachment holes should be positioned over the hinge line.

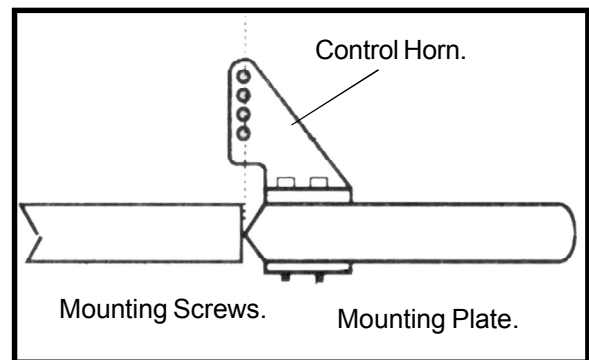
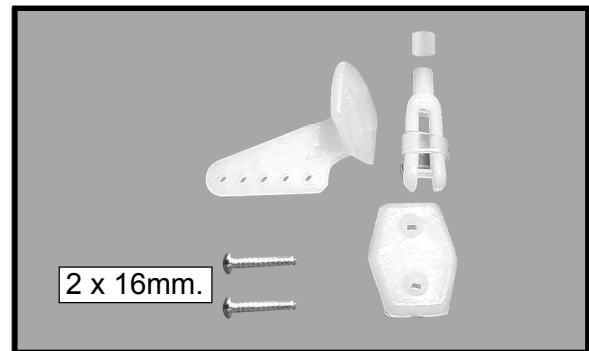

□ 3) Using a 1.5mm drill bit and the control horns as a guide, drill the mounting holes through the elevator halves.

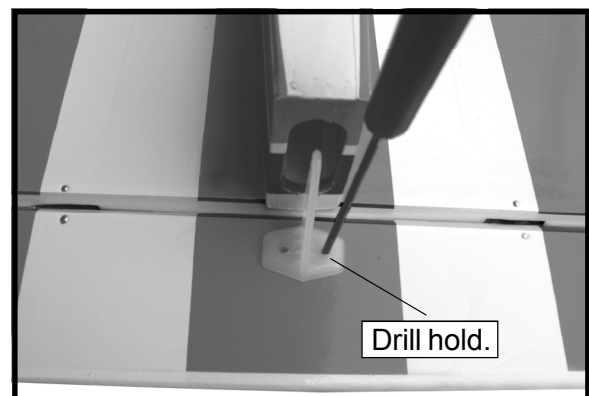

Instruction Manual.

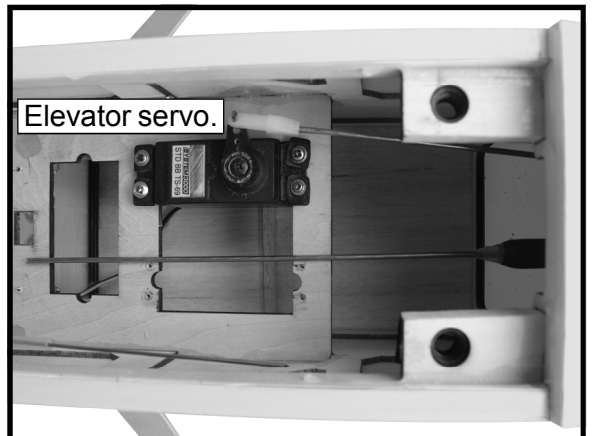
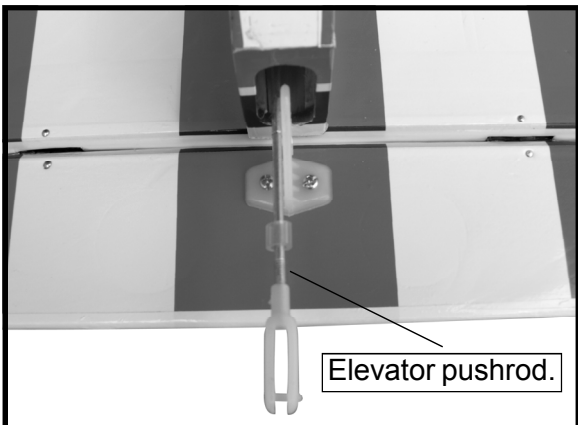
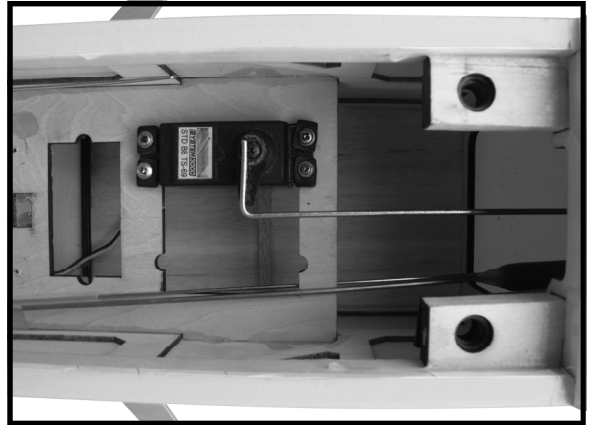
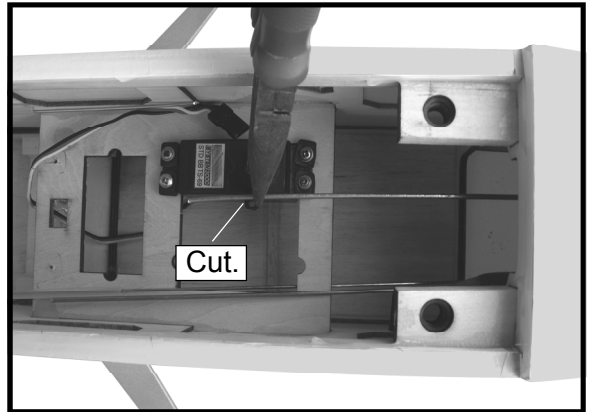
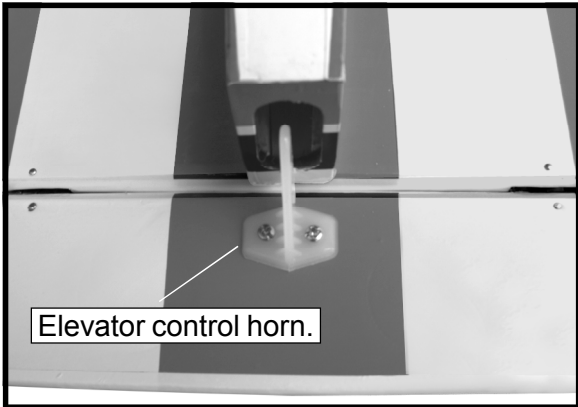
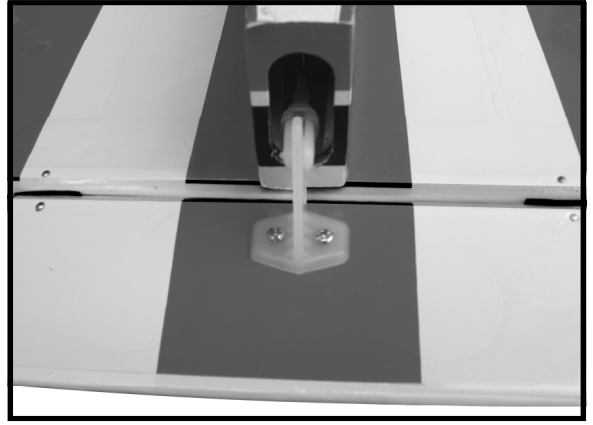
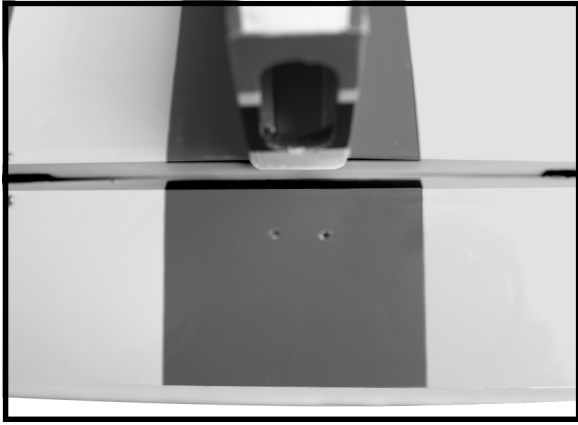

EXCEL 2000.

VERTICAL STABILIZER INSTALLATION.

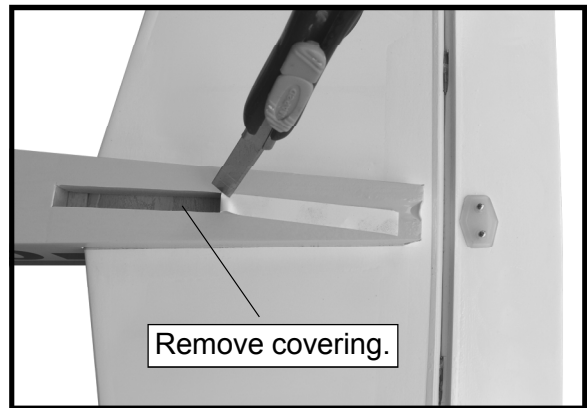
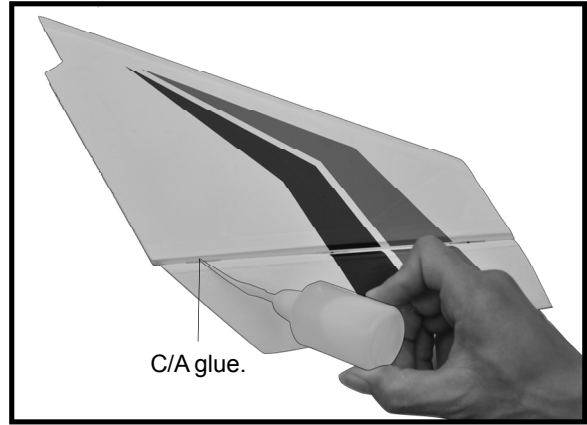
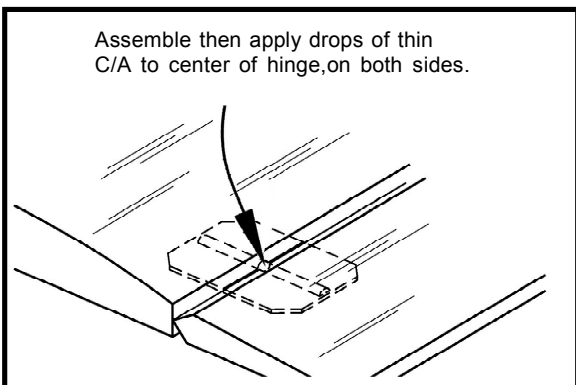
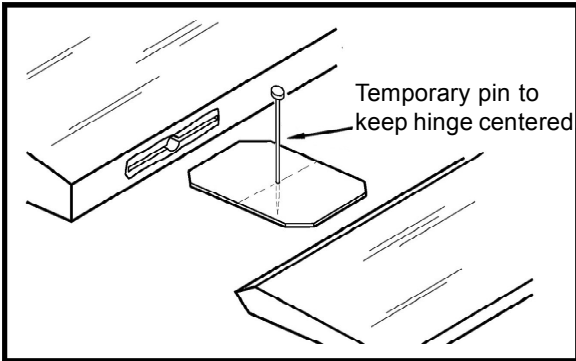
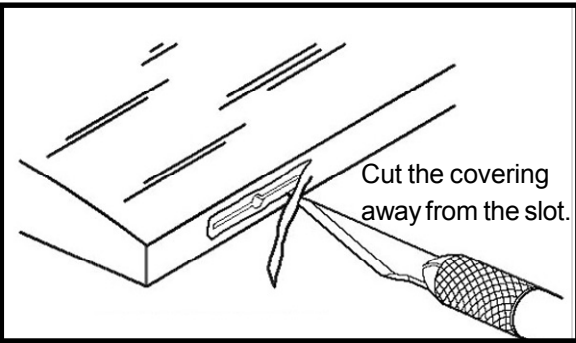
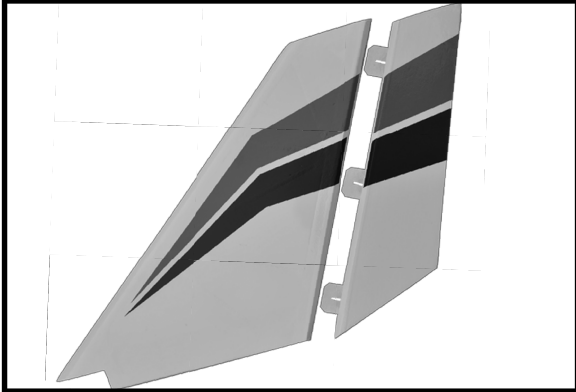
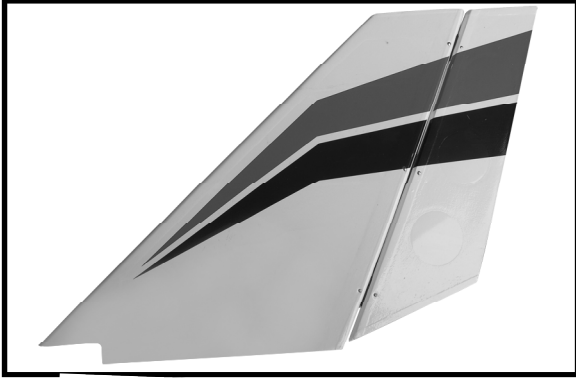

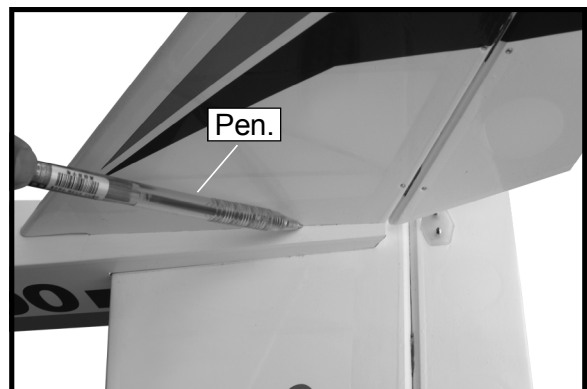
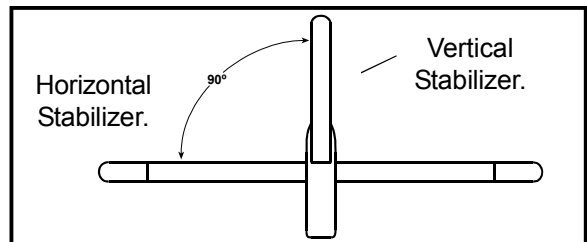

□ 1) Slide the vertical stabilizer into the slot in the top of the fuselage. The bottom edge of the stabilizer should also be firmly pushed against the top of the horizontal stabilizer.

□ 2) While holding the vertical stabilizer firmly in place, use a pen and draw a line on each side of the vertical stabilizer where it meets the top of the fuselage.

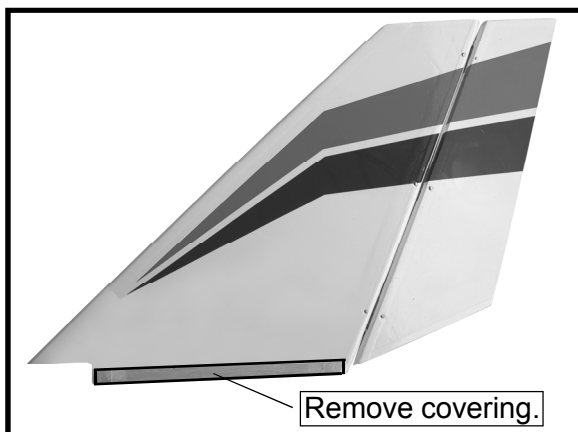

- 3) Remove the vertical stabilizer. Using a modeling knife, remove the covering from below the lines you drew. Also remove the covering from the bottom edge of the stabilizer and the bottom and top edges of the filler block. Leave the covering in place on the sides of the filler block.



 *When cutting through the covering to remove it, cut with only enough pressure to only cut through the covering itself. Cutting into the balsa structure may weaken it.*

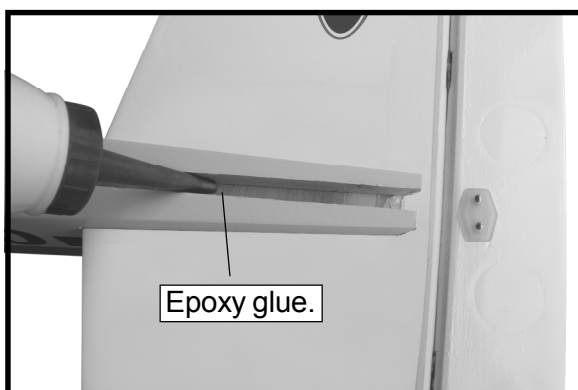

- 4) Slide the vertical stabilizer back in place. Using a triangle, check to ensure that the vertical stabilizer is aligned 90° to the horizontal stabilizer.

- 5) When you are sure that everything is aligned correctly, mix up a generous amount of Flash 30 Minute Epoxy. Apply a thin layer to the mounting slot in the top of the fuselage and to the sides and bottom of the vertical stabilizer mounting area. Apply epoxy to the bottom and top edges of the filler block and to the lower hinge also. Set the stabilizer in place and re-align. Double check all of your measurements once more before the epoxy cures. Hold the stabilizer in place with T-pins or masking tape and remove any excess epoxy using a paper towel and rubbing alcohol. Allow the epoxy to fully cure before proceeding.

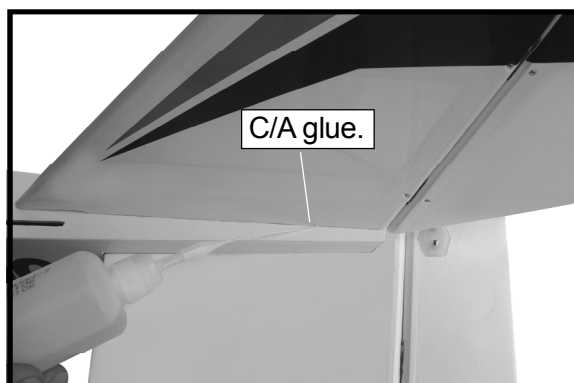

RUDDER CONTROL HORN - PUSHROD INSTALLATION.

- 1) Locate the two nylon control horns, two nylon control horn backplates and four M2 x 12mm machine screws.
- 2) Position the rudder horn on the bottom side of rudder.

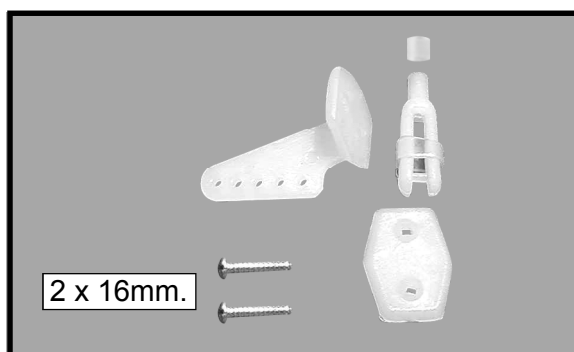

- 3) Using a 1.5mm drill bit and the control horns as a guide, drill the mounting holes through the rudder halves.

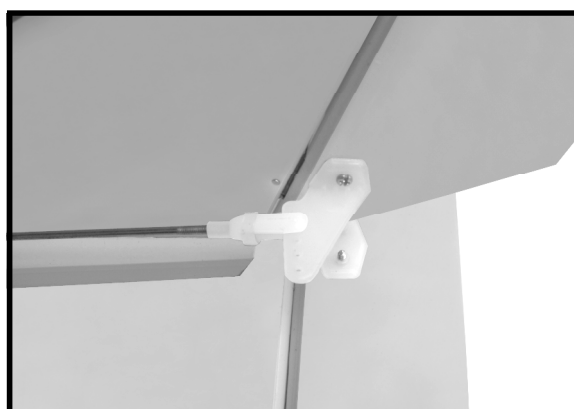
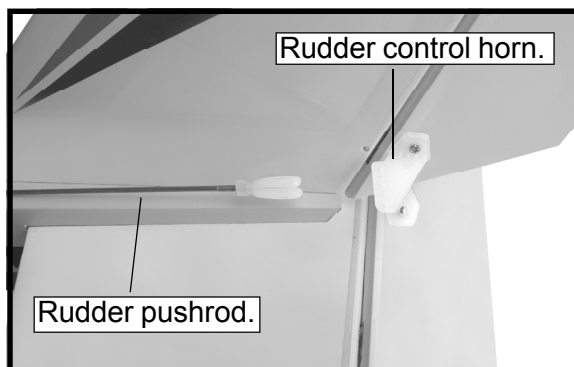

EXCEL 2000.

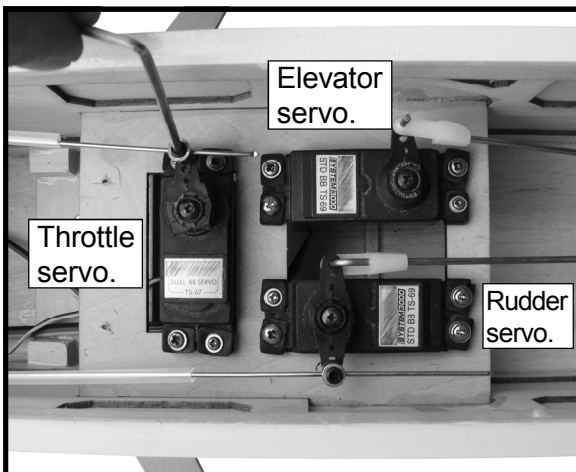
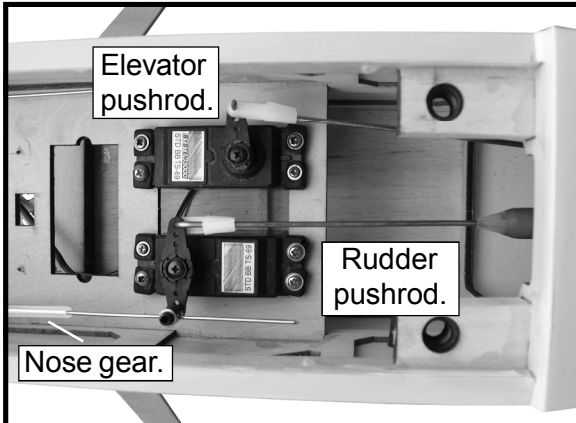
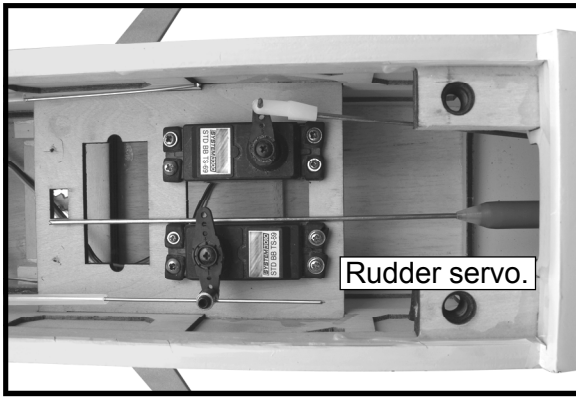

INSTALLING THE SWITCH.

□ 1) Cut out the switch hole using a modeling knife. Use a 2mm drill bit and drill out the two mounting holes through the fuselage side.

□ 2) Secure the switch in place using the two machine screws provided with the radio system.

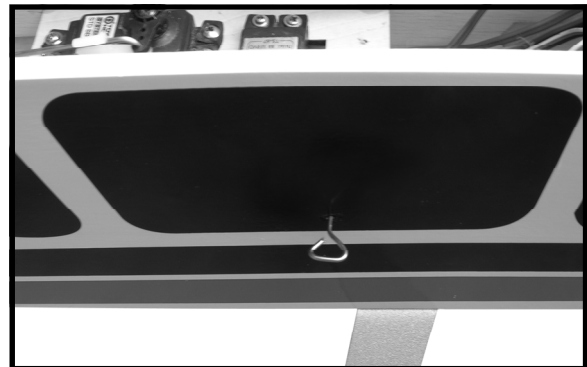
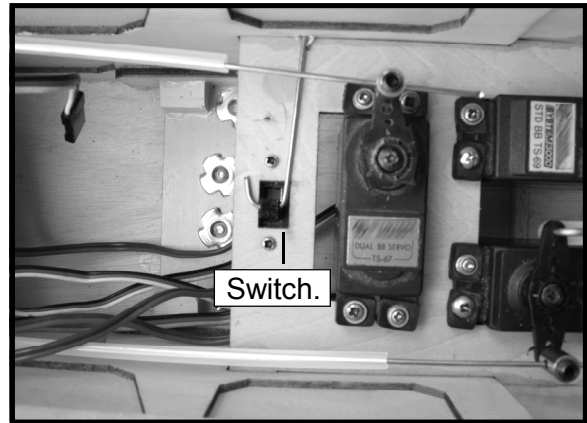
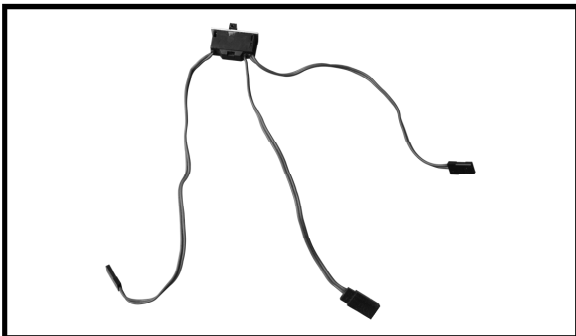

INSTALLING THE RECEIVER AND BATTERY.

□ 1) Plug the servo leads and the switch lead into the receiver. Plug the battery pack lead into the switch.

□ 2) Wrap the receiver and battery pack in the protective foam to protect them from vibration.

□ 3) Do not permanently secure the receiver and battery until after balancing the model.

□ 4) Using a 2mm drill bit, drill a hole through the side of the fuselage, near the receiver, for the antenna to exit.

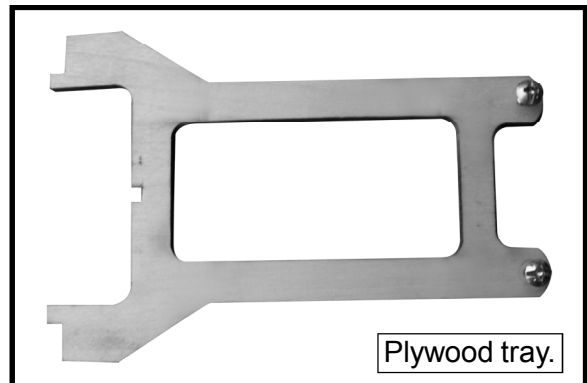

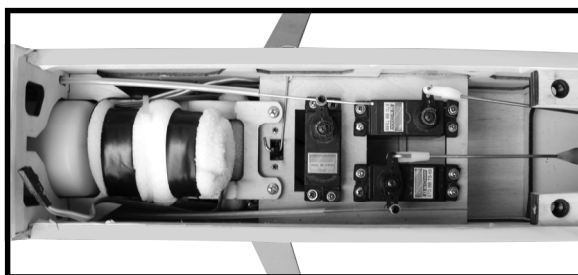
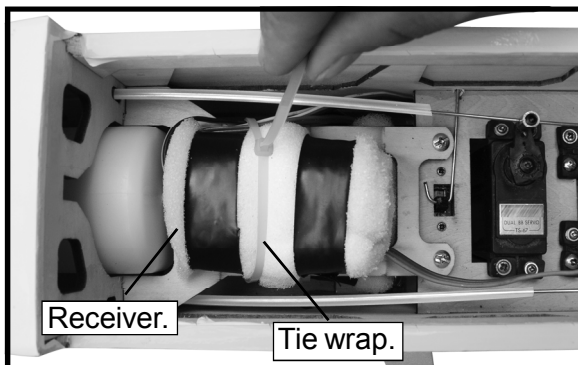
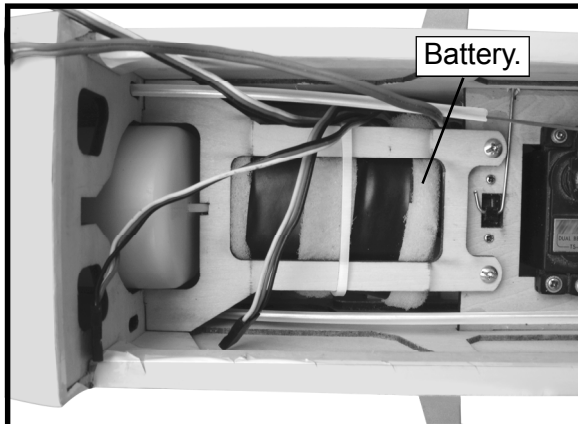
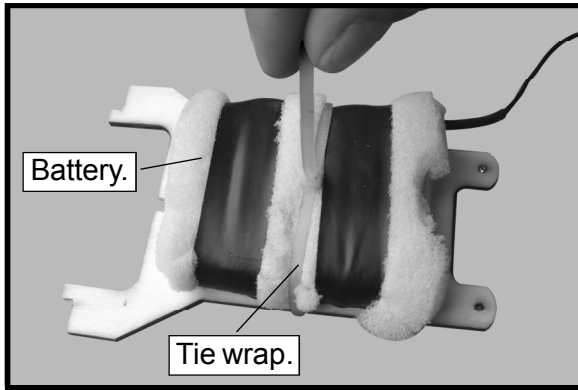

ATTACHMENT WING-FUSELAGE.

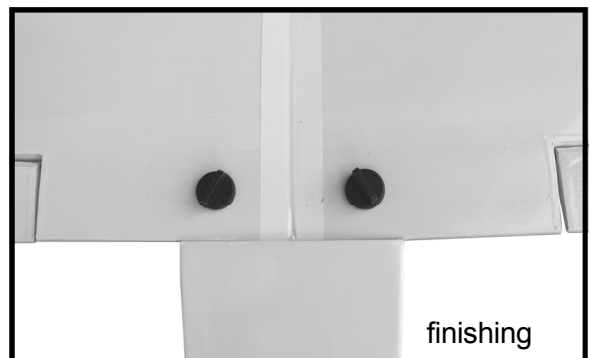
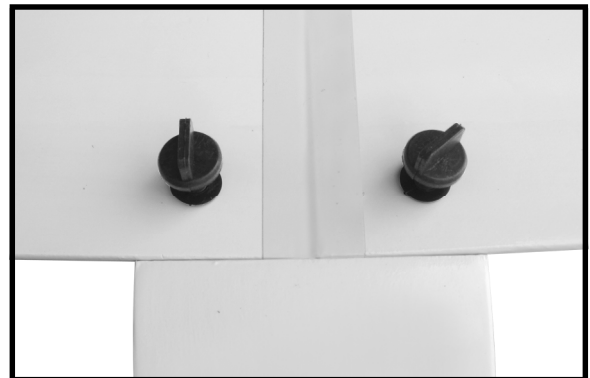
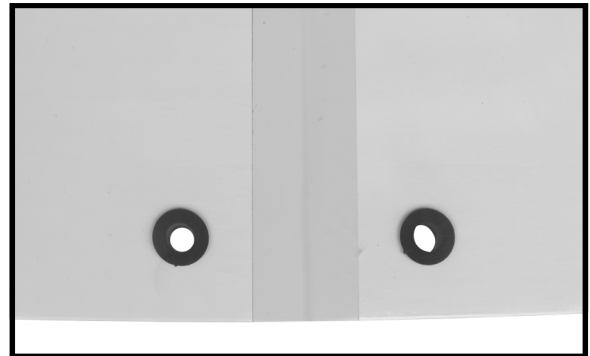
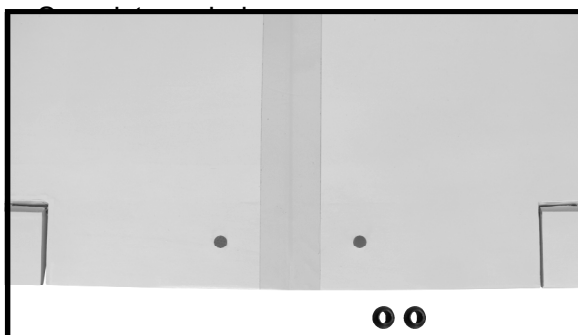

BALANCING.

❑ 1) It is critical that your airplane be balanced correctly. Improper balance will cause your plane to lose control and crash.

THE CENTER OF GRAVITY IS LOCATED **74mm** BACK FROM THE LEADING EDGE OF THE WING.

❑ 2) Turn the airplane upside down. Place your fingers on the masking tape and carefully lift the plane .

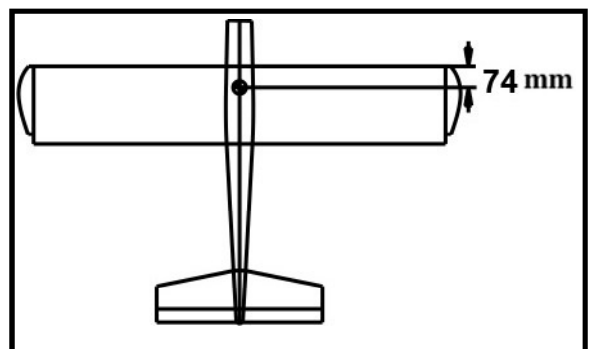

CONTROL THROWS.

1) We highly recommend setting up a plane using the control throws listed.

2) The control throws should be measured at the widest point of each control surface.

3) Check to be sure the control surfaces move in the correct directions.

Ailerons : 15mm up 15mm down.

Elevator : 10mm up 10mm down.

Rudder : 15mm right 15mm left.

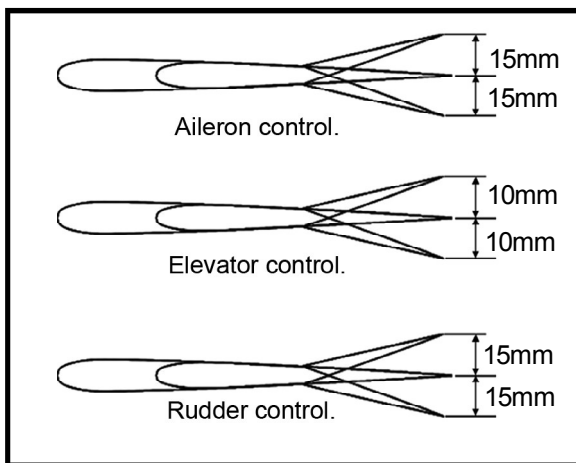

PRE-FLIGHT CHECK.

1) Completely charge your transmitter and receiver batteries before your first day of flying.

2) Check every bolt and every glue joint in your plane to ensure that everything is tight and well bonded.

3) Double check the balance of the airplane.

4) Check the control surface.

5) Check the receiver antenna . It should be fully extended and not coiled up inside the fuselage.

6) Properly balance the propeller.

We wish you enjoy.